

0.7 A Dual H-Bridge Motor Driver with 3.0V/5.0V Compatible Logic I/O

The 17529 is a monolithic dual H-Bridge power IC ideal for portable electronic applications containing bipolar step motors and/or brush DC-motors (e.g., cameras and disk drive head positioners).

The 17529 operates from 2.0 V to 6.8 V, with independent control of each H-Bridge via parallel MCU interface (3.0 V- and 5.0 V-compatible logic). The device features on-board charge pump, as well as built-in shoot-through current protection and an undervoltage shutdown function.

The 17529 has four operating modes: Forward, Reverse, Brake, and Tri-States (High Impedance). The 17529 has a low total $R_{DS(ON)}$ of 1.2 Ω (max @ 25°C).

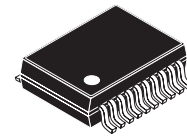
The 17529's low output resistance and high slew rates provide efficient drive for many types of micromotors.

Features

- Low Total $R_{DS(ON)}$ 0.7 Ω (Typ), 1.2 Ω (Max) @ 25°C
- Output Current 0.7 A (DC), 1.4 A (Peak)
- Shoot-Through Current Protection Circuit
- 3.0 V/5.0 V CMOS-Compatible Inputs
- PWM Control Input Frequency up to 200 kHz
- Built-In Charge Pump Circuit
- Low Power Consumption
- Undervoltage Detection and Shutdown Circuit
- Pb-Free Packaging Designated by Suffix Code EV

17529

DUAL H-BRIDGE



**EV SUFFIX (PB-FREE)
 98ASA10616D
 20-TERMINAL VMFP**

ORDERING INFORMATION

Device	Temperature Range (T_A)	Package
MPC17529EV/EL	-20°C to 65°C	20 VMFP

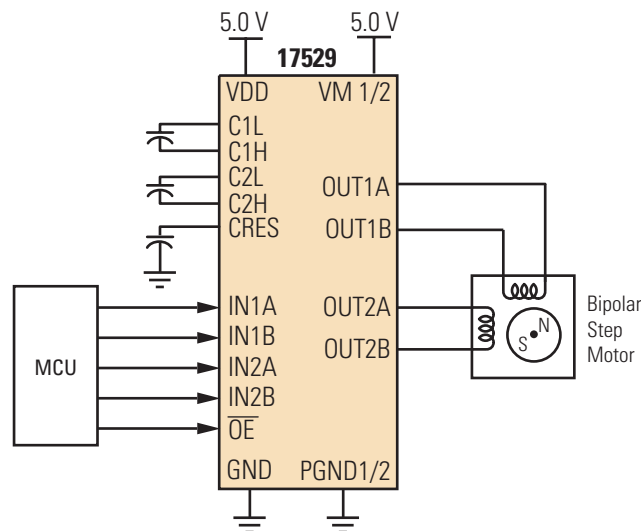


Figure 1. 17529 Simplified Application Diagram

* This document contains certain information on a new product. Specifications and information herein are subject to change without notice.

INTERNAL BLOCK DIAGRAM

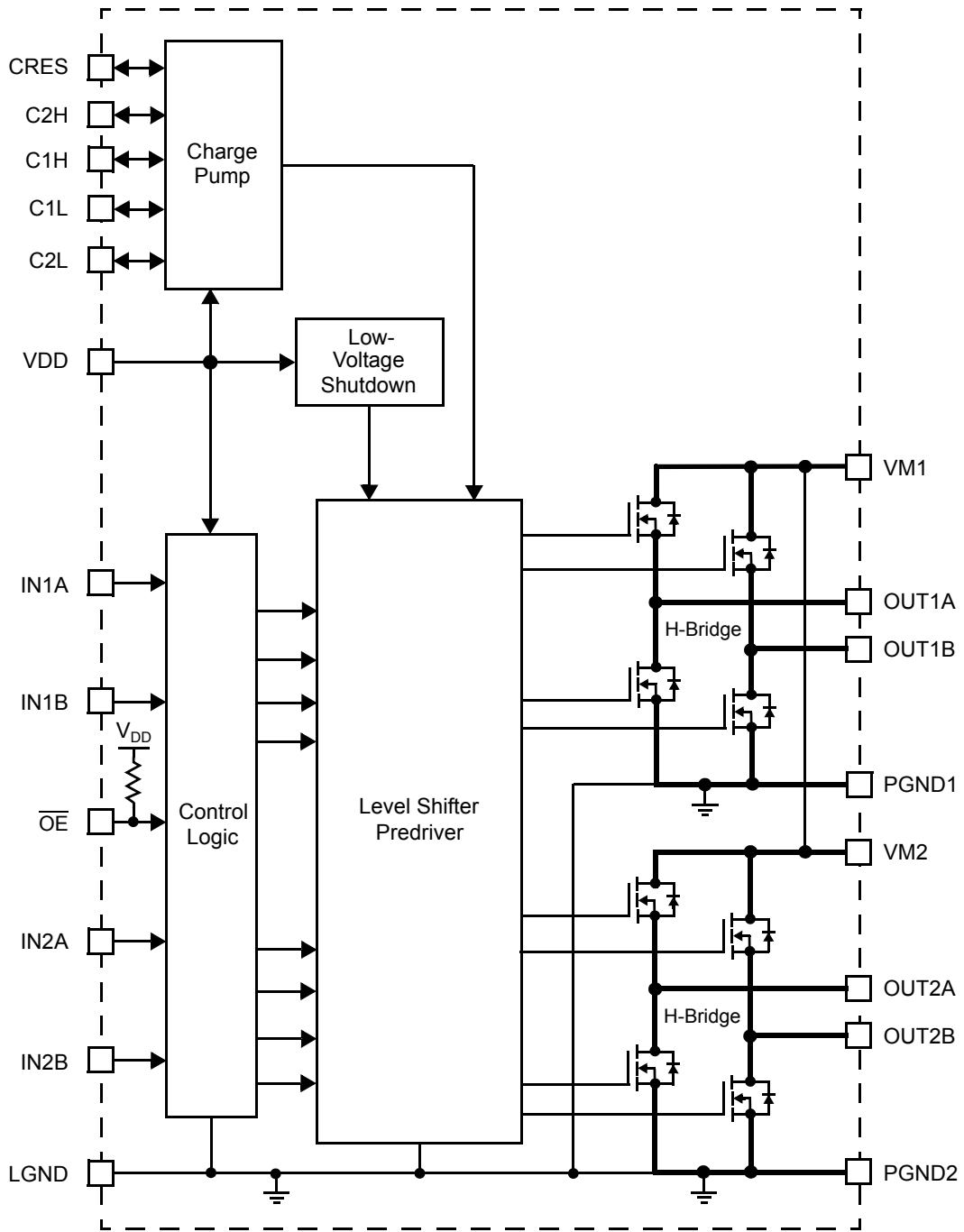


Figure 2. 17529 Simplified Internal Block Diagram

TERMINAL CONNECTIONS

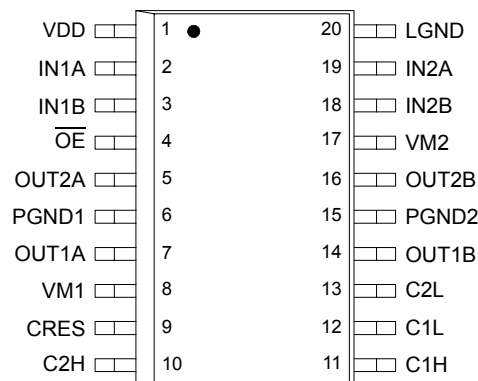


Figure 3. 17529 Terminal Connections

Table 1. Terminal Function Description

Terminal	Terminal Name	Formal Name	Definition
1	VDD	Control Circuit Power Supply	Positive power source connection for control circuit.
2	IN1A	Logic Input Control 1A	Logic input control of OUT1A (refer to Table 5, Truth Table , page Z).
3	IN1B	Logic Input Control 1B	Logic input control of OUT1B (refer to Table 5, Truth Table , page Z).
4	$\overline{\text{OE}}$	Output Enable	Logic output Enable control of H-Bridges (Low = True).
5	OUT2A	H-Bridge Output 2A	Output A of H-Bridge channel 2.
6	PGND1	Power Ground 1	High-current power ground 1.
7	OUT1A	H-Bridge Output 1A	Output A of H-Bridge channel 1.
8	VM1	Motor Drive Power Supply 1	Positive power source connection for H-Bridge 1 (Motor Drive Power Supply).
9	CRES	Predriver Power Supply	Internal triple charge pump output as predriver power supply.
10	C2H	Charge Pump 2H	Charge pump bucket capacitor 2 (positive pole).
11	C1H	Charge Pump 1H	Charge pump bucket capacitor 1 (positive pole).
12	C1L	Charge Pump 1L	Charge pump bucket capacitor 1 (negative pole).
13	C2L	Charge Pump 2L	Charge pump bucket capacitor 2 (negative pole).
14	OUT1B	H-Bridge Output 1B	Output B of H-Bridge channel 1.
15	PGND2	Power Ground 2	High-current power ground 2.
16	OUT2B	H-Bridge Output 2B	Output B of H-Bridge channel 2.
17	VM2	Motor Drive Power Supply 2	Positive power source connection for H-Bridge 2 (Motor Drive Power Supply).
18	IN2B	Logic Input Control 2B	Logic input control of OUT2B (refer to Table 5, Truth Table , page Z).
19	IN2A	Logic Input Control 2A	Logic input control of OUT2A (refer to Table 5, Truth Table , page Z).
20	LGND	Logic Ground	Low-current logic signal ground.

MAXIMUM RATINGS

Table 2. Maximum Ratings

All voltages are with respect to ground unless otherwise noted. Exceeding the ratings may cause a malfunction or permanent damage to the device.

Rating	Symbol	Value	Unit
Motor Supply Voltage	V_M	-0.5 to 8.0	V
Charge Pump Output Voltage	V_{CRES}	-0.5 to 14	V
Logic Supply Voltage	V_{DD}	-0.5 to 7.0	V
Signal Input Voltage	V_{IN}	-0.5 to $V_{DD}+0.5$	V
Driver Output Current			A
Continuous	I_O	0.7	
Peak ⁽¹⁾	I_{OPK}	1.4	
ESD Voltage			V
Human Body Model ⁽²⁾	V_{ESD1}	±1500	
Machine Model ⁽³⁾	V_{ESD2}	±200	
Operating Junction Temperature	T_J	-20 to 150	°C
Operating Ambient Temperature	T_A	-20 to 65	°C
Storage Temperature Range	T_{STG}	-65 to 150	°C
Thermal Resistance ⁽⁴⁾	$R_{\theta JA}$	120	°C/W
Power Dissipation ⁽⁵⁾	P_D	1040	mW
Soldering Temperature ⁽⁶⁾	T_{SOLDER}	260	°C

Notes

- $T_A = 25^\circ\text{C}$, 10 ms pulse at 200 ms interval.
- ESD1 testing is performed in accordance with the Human Body Model ($C_{ZAP} = 100 \text{ pF}$, $R_{ZAP} = 1500 \ \Omega$).
- ESD2 testing is performed in accordance with the Machine Model ($C_{ZAP} = 200 \text{ pF}$, $R_{ZAP} = 0 \ \Omega$).
- Mounted on 37 x 50 Cu area (1.6 mm FR-4 PCB).
- $T_A = 25^\circ\text{C}$.
- Soldering temperature limit is for 10 seconds maximum duration. Not designed for immersion soldering. Exceeding these limits may cause malfunction or permanent damage to the device.

STATIC ELECTRICAL CHARACTERISTICS

Table 3. Static Electrical Characteristics

 Characteristics noted under conditions $T_A = 25^\circ\text{C}$, $V_{DD} = V_M = 5.0\text{ V}$, $\text{GND} = 0\text{ V}$ unless otherwise noted.

Characteristic	Symbol	Min	Typ	Max	Unit
POWER (VM1, VM2, VDD)					
Motor Supply Voltage	V_M	2.0	5.0	6.8	V
Logic Supply Voltage	V_{DD}	2.7	5.0	5.6	V
Driver Quiescent Supply Current (No Signal Input)	I_{QM}	–	–	1.0	μA
Logic Quiescent Supply Current (No Signal Input) ⁽⁷⁾	I_{QVDD}	–	–	1.0	mA
Operating Power Supply Current					mA
Logic Supply Current ⁽⁸⁾	I_{DVDD}	–	–	3.0	
Charge Pump Circuit Supply Current ⁽⁹⁾	I_{CRES}	–	–	0.7	
Low V_{DD} Detection Voltage ⁽¹⁰⁾	V_{DDDET}	1.5	2.0	2.5	V
Driver Output ON Resistance ⁽¹¹⁾	$R_{DS(ON)}$	–	0.7	1.2	Ohms
GATE DRIVE (C1L–C1H, C2L–C2H, CRES)					
Gate Drive Voltage	V_{CRES}	12	13	13.5	V
Recommended External Capacitance (C1L–C1H, C2L–C2H, C_{RES} –GND)	C_{CP}	0.01	0.1	1.0	μF
CONTROL LOGIC ($\overline{\text{OE}}$, N1A, N1B, N2A, N2B)					
Logic Input Voltage	V_{IN}	0.0	–	V_{DD}	V
Logic Inputs ($2.7\text{ V} < V_{DD} < 5.7\text{ V}$)					
High-Level Input Voltage	V_{IH}	$V_{DD} \times 0.7$	–	–	V
Low-Level Input Voltage	V_{IL}	–	–	$V_{DD} \times 0.3$	V
High-Level Input Current	I_{IH}	–	–	1.0	μA
Low-Level Input Current	I_{IL}	-1.0	–	–	μA
$\overline{\text{OE}}$ Terminal Input Current Low	$I_{OIL\overline{\text{OE}}}$	–	50	100	μA

Notes

7. I_{QVDD} includes the current to predriver circuit.
8. I_{VDD} includes the current to predriver circuit at $f_{IN} = 100\text{ kHz}$.
9. At $f_{IN} = 20\text{ kHz}$.
10. Detection voltage is defined as when the output becomes high-impedance after V_{DD} drops below the detection threshold. When the gate voltage V_{CRES} is applied from an external source, $V_{CRES} = 7.5\text{ V}$.
11. Source + sink at $I_O = 0.7\text{ A}$.

DYNAMIC ELECTRICAL CHARACTERISTICS

Table 4. Dynamic Electrical Characteristics

Characteristics noted under conditions $T_A = 25^\circ\text{C}$, $V_{DD} = V_M = 5.0\text{ V}$, $\text{GND} = 0\text{ V}$ unless otherwise noted.

Characteristic	Symbol	Min	Typ	Max	Unit
INPUT (IN1A, IN1B, OE, IN2A, IN2B)					
Pulse Input Frequency	f_{IN}	–	–	200	kHz
Input Pulse Rise Time ⁽¹²⁾	t_R	–	–	(13) 1.0	μs
Input Pulse Fall Time ⁽¹⁴⁾	t_F	–	–	(13) 1.0	μs
OUTPUT (OUT1A, OUT1B, OUT2A, OUT2B)					
Propagation Delay Time ⁽¹⁵⁾					μs
Turn-ON Time	t_{PLH}	–	0.1	0.5	
Turn-OFF Time	t_{PHL}	–	0.1	0.5	
Charge Pump Wake-Up Time ⁽¹⁶⁾	t_{VGON}	–	1.0	3.0	ms
Low-Voltage Detection Time	t_{VDDDET}	–	–	10	ms

Notes

12. Time is defined between 10% and 90%.
13. That is, the input waveform slope must be steeper than this.
14. Time is defined between 90% and 10%.
15. Load of Output is $8.0\ \Omega$ resistance.
16. $C_{CP} = 0.1\ \mu\text{F}$.

TIMING DIAGRAMS

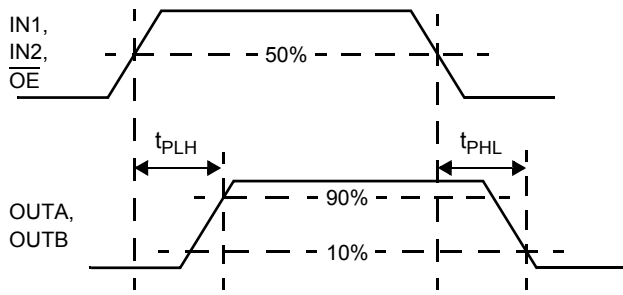
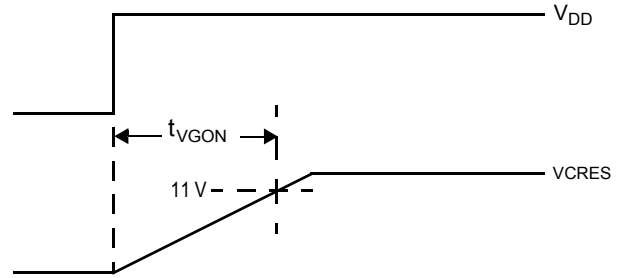
Figure 4. t_{PLH} , t_{PHL} , and t_{PZH} Timing

Figure 6. Charge Pump Timing Diagram

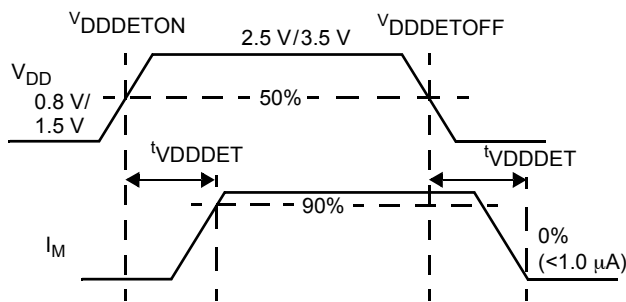


Figure 5. Low-Voltage Detection Timing Diagram

Table 5. Truth Table

INPUT			OUTPUT	
\overline{OE}	IN1A IN2A	IN1B IN2B	OUT1A OUT2A	OUT1B OUT2B
L	L	L	L	L
L	H	L	H	L
L	L	H	L	H
L	H	H	Z	Z
H	X	X	Z	Z

H = High.

L = Low.

Z = High impedance.

X = Don't care.

 \overline{OE} terminal is pulled up to V_{DD} with internal resistance.

SYSTEM/APPLICATION INFORMATION

INTRODUCTION

The 17529 is a monolithic dual H-Bridge ideal for portable electronic applications to control bipolar step motors and brush DC motors such as those found in camera lens assemblies, camera shutters, optical disk drives, etc. The 17529 operates from 2.0 V to 6.8 V, providing dual H-bridge motor drivers with parallel 3.0 V- or 5.0 V-compatible I/O. The device features an on-board charge pump, as well as built-in shoot-through current protection and undervoltage shutdown.

The 17529 has four operating modes: Forward, Reverse, Brake, and Tri-Stated (High Impedance). The MOSFETs comprising the output bridge have a total source + sink $R_{DS(ON)} \leq 1.2 \Omega$.

The 17529 can simultaneously drive two brush DC motors or, as shown in the simplified application diagram on page 1, one bipolar step motor. The drivers are designed to be PWM'ed at frequencies up to 200 kHz.

FUNCTIONAL TERMINAL DESCRIPTION

CONTROL CIRCUIT POWER SUPPLY (VDD)

The VDD terminal carries the logic supply voltage and current into the logic sections of the IC. VDD has an undervoltage threshold. If the supply voltage drops below the undervoltage threshold, the output power stage switches to a tri-state condition. When the supply voltage returns to a level that is above the threshold, the power stage automatically resumes normal operation according to the established condition of the input terminals.

LOGIC INPUT CONTROL (IN1A, IN1B, IN2A, AND IN2B)

These logic input terminals control each H-Bridge output. IN1A logic HIGH = OUT1A HIGH. However, if all inputs are taken HIGH, the outputs bridges are both tri-stated (refer to [Table 5, Truth Table](#), page 7).

OUTPUT ENABLE (OE)

The \overline{OE} terminal is a LOW = TRUE enable input. When \overline{OE} = HIGH, all H-Bridge outputs (OUT1A, OUT1B, OUT2A, and OUT2B) are tri-stated (high-impedance), regardless of logic input (IN1A, IN1B, IN2A, and IN2B) states.

H-BRIDGE OUTPUT (OUT1A, OUT1B, OUT2A, AND OUT2B)

These terminals provide connection to the outputs of each of the internal H-Bridges (see [Figure 2, 17529 Simplified Internal Block Diagram](#), page 2).

MOTOR DRIVE POWER SUPPLY (VM1 AND VM2)

The VM terminals carry the main supply voltage and current into the power sections of the IC. This supply then becomes controlled and/or modulated by the IC as it delivers the power to the loads attached between the output terminals. All VM terminals must be connected together on the printed circuit board.

CHARGE PUMP (C1L AND C1H, C2L AND C2H)

These two pairs of terminals, the C1L and C1H and the C2L and C2H, connect to the external bucket capacitors required by the internal charge pump. The typical value for the bucket capacitors is 0.1 μF .

PREDRIVER POWER SUPPLY (C_{RES})

The C_{RES} terminal is the output of the internal charge pump. Its output voltage is approximately three times the V_{DD} voltage. The VCRES voltage is power supply for internal predriver circuit of H-Bridges.

POWER GROUND (PGND)

Power ground terminals. They must be tied together on the PCB.

LOGIC GROUND (LGND)

Logic ground terminal.

This paragraph is boilerplate - you may add to it but, can not change wording. You may change numeric values

APPLICATIONS

TYPICAL APPLICATION

Figure 7 shows a typical application for the 17529. When applying the gate voltage to the C_{RES} terminal from an external source, be sure to connect it via a resistor equal to, or greater than, $R_G = V_{CRES}/0.02 \Omega$.

The internal charge pump of this device is generated from the VDD supply; therefore, care must be taken to provide sufficient gate-source voltage for the high-side MOSFETs when $V_M \gg V_{DD}$ (e.g., $V_M = 5.0 \text{ V}$, $V_{DD} = 3.0 \text{ V}$), in order to ensure full enhancement of the high-side MOSFET channels.

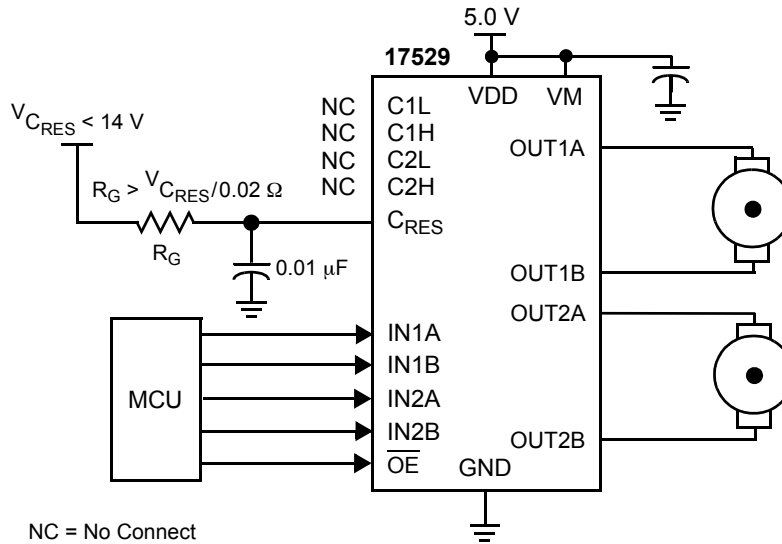


Figure 7. 17529 Typical Application Diagram

CONDUCTED ELECTROMOTIVE FORCE (CEMF) SNUBBING TECHNIQUES

Care must be taken to protect the IC from potentially damaging CEMF spikes induced when commutating currents in inductive loads. Typical practice is to provide snubbing of voltage transients by placing a capacitor or zener at the supply terminal (VM) (see Figure 8).

PCB LAYOUT

When designing the printed circuit board (PCB), connect sufficient capacitance between power supply and ground terminals to ensure proper filtering from transients. For all high-current paths, use wide copper traces and shortest possible distances.

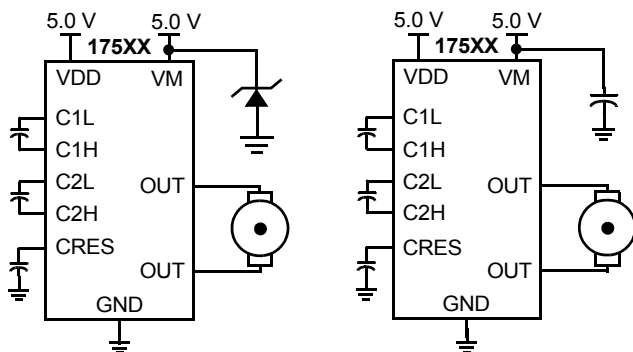
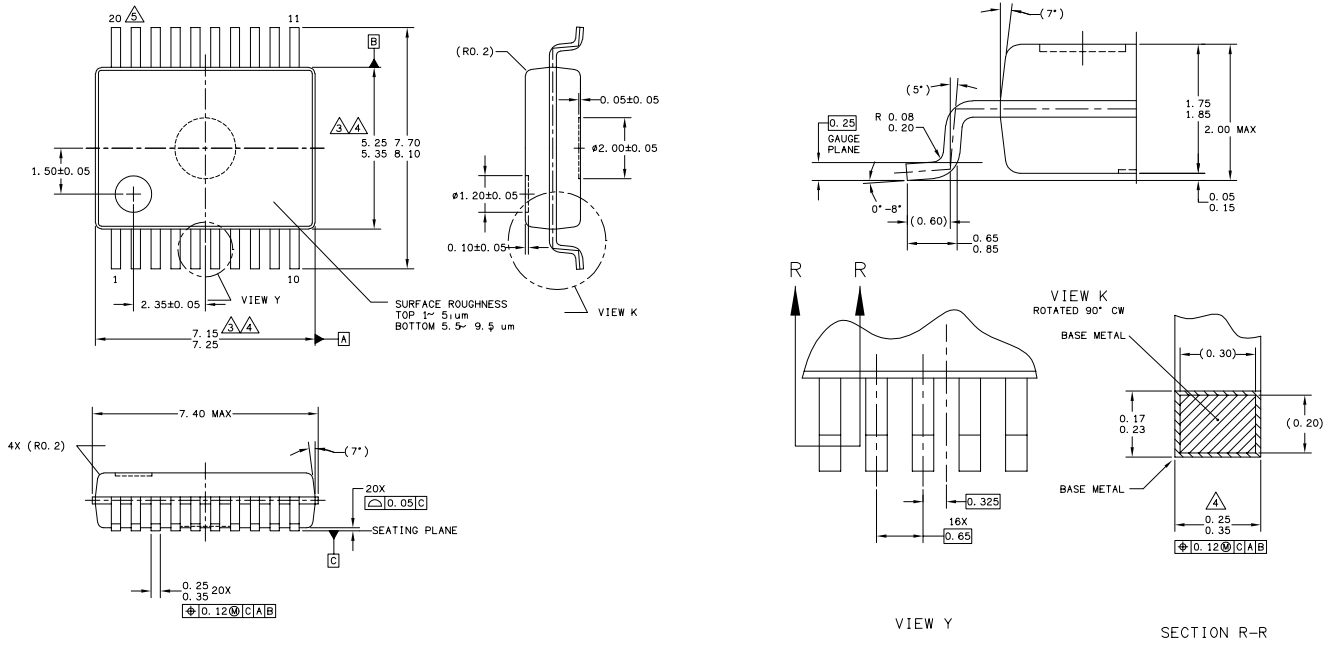


Figure 8. CEMF Snubbing Techniques

PACKAGE DIMENSIONS

For the most current package revision, visit www.freescale.com and perform a keyword search using the 98A listed below.



EV (Pb-FREE) SUFFIX
20-LEAD VMFP
PLASTIC PACKAGE
98ASA10616D
ISSUE A

REVISION HISTORY

Revision	Date	Description of Changes
2.0	9/2005	<ul style="list-style-type: none">• Implemented Revision History page• Converted to Freescale format

How to Reach Us:

Home Page:

www.freescale.com

E-mail:

support@freescale.com

USA/Europe or Locations Not Listed:

Freescale Semiconductor
Technical Information Center, CH370
1300 N. Alma School Road
Chandler, Arizona 85224
+1-800-521-6274 or +1-480-768-2130
support@freescale.com

Europe, Middle East, and Africa:

Freescale Halbleiter Deutschland GmbH
Technical Information Center
Schatzbogen 7
81829 Muenchen, Germany
+44 1296 380 456 (English)
+46 8 52200080 (English)
+49 89 92103 559 (German)
+33 1 69 35 48 48 (French)
support@freescale.com

Japan:

Freescale Semiconductor Japan Ltd.
Headquarters
ARCO Tower 15F
1-8-1, Shimo-Meguro, Meguro-ku,
Tokyo 153-0064
Japan
0120 191014 or +81 3 5437 9125
support.japan@freescale.com

Asia/Pacific:

Freescale Semiconductor Hong Kong Ltd.
Technical Information Center
2 Dai King Street
Tai Po Industrial Estate
Tai Po, N.T., Hong Kong
+800 2666 8080
support.asia@freescale.com

For Literature Requests Only:

Freescale Semiconductor Literature Distribution Center
P.O. Box 5405
Denver, Colorado 80217
1-800-441-2447 or 303-675-2140
Fax: 303-675-2150
LDCForFreescaleSemiconductor@hibbertgroup.com

Information in this document is provided solely to enable system and software implementers to use Freescale Semiconductor products. There are no express or implied copyright licenses granted hereunder to design or fabricate any integrated circuits or integrated circuits based on the information in this document.

Freescale Semiconductor reserves the right to make changes without further notice to any products herein. Freescale Semiconductor makes no warranty, representation or guarantee regarding the suitability of its products for any particular purpose, nor does Freescale Semiconductor assume any liability arising out of the application or use of any product or circuit, and specifically disclaims any and all liability, including without limitation consequential or incidental damages. "Typical" parameters that may be provided in Freescale Semiconductor data sheets and/or specifications can and do vary in different applications and actual performance may vary over time. All operating parameters, including "Typicals", must be validated for each customer application by customer's technical experts. Freescale Semiconductor does not convey any license under its patent rights nor the rights of others. Freescale Semiconductor products are not designed, intended, or authorized for use as components in systems intended for surgical implant into the body, or other applications intended to support or sustain life, or for any other application in which the failure of the Freescale Semiconductor product could create a situation where personal injury or death may occur. Should Buyer purchase or use Freescale Semiconductor products for any such unintended or unauthorized application, Buyer shall indemnify and hold Freescale Semiconductor and its officers, employees, subsidiaries, affiliates, and distributors harmless against all claims, costs, damages, and expenses, and reasonable attorney fees arising out of, directly or indirectly, any claim of personal injury or death associated with such unintended or unauthorized use, even if such claim alleges that Freescale Semiconductor was negligent regarding the design or manufacture of the part.

Freescale™ and the Freescale logo are trademarks of Freescale Semiconductor, Inc. All other product or service names are the property of their respective owners.

© Freescale Semiconductor, Inc., 2005. All rights reserved.

